

Retrospective and near real-time tests of GSI-based EnKF-Var hybrid data assimilation system for HWRF with airborne radar data



Xuguang Wang, Xu Lu, Yongzuo Li
University of Oklahoma, Norman, OK

In collaboration with

Mingjing Tong , Vijay Tallapragada
National Center for Environmental Prediction, College Park, MD

Jeff Whitaker, Henry Winterbottom
Earth System Research Lab, Boulder, CO

Acknowledge HRD to make SFMR, flight level data and airborne radar data available



Background

- ❑ The GSI-based hybrid DA system (currently a 3D system, 3DEnsVar) showed significant improvement for global forecast compared to GSI 3DVAR and became operational on May 22, 2012 for Global Forecast System (GFS).
- ❑ The system has been extended to 4D (4DEnsVar). Unlike 4DVar, 4DEnsVar conveniently avoids the tangent linear and adjoint of the forecast model.



GSI hybrid for GFS:

GSI 3DVar vs. 3DEnsVar Hybrid vs. EnKF

120h temperature fit to obs.

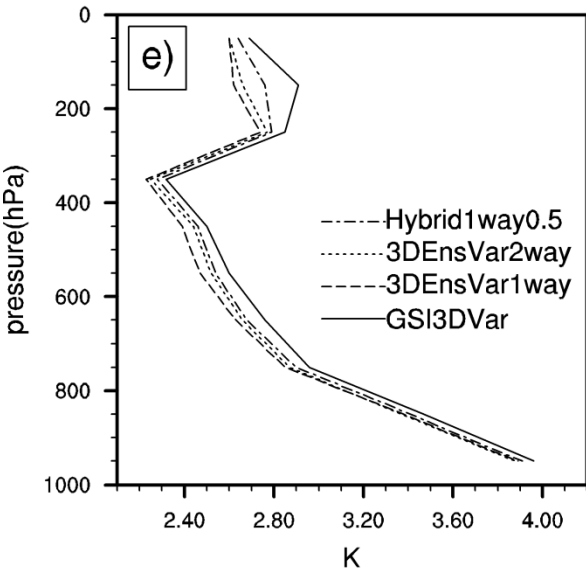

120h wind fit to obs.

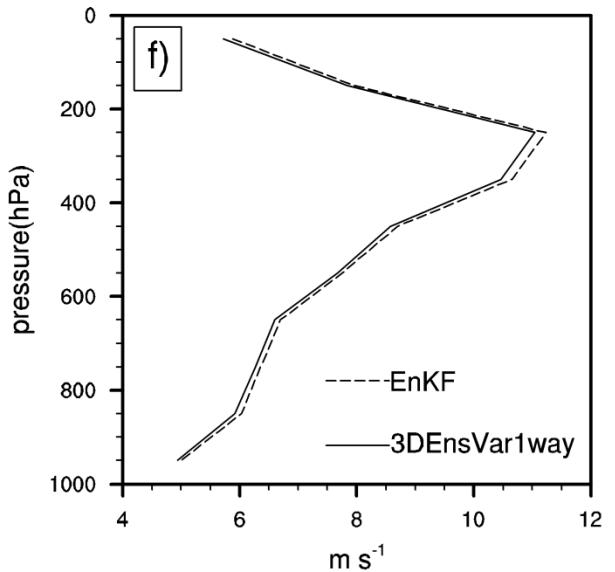
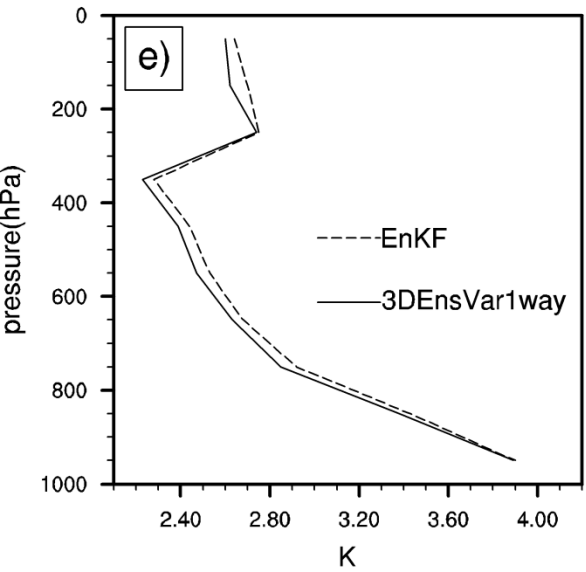
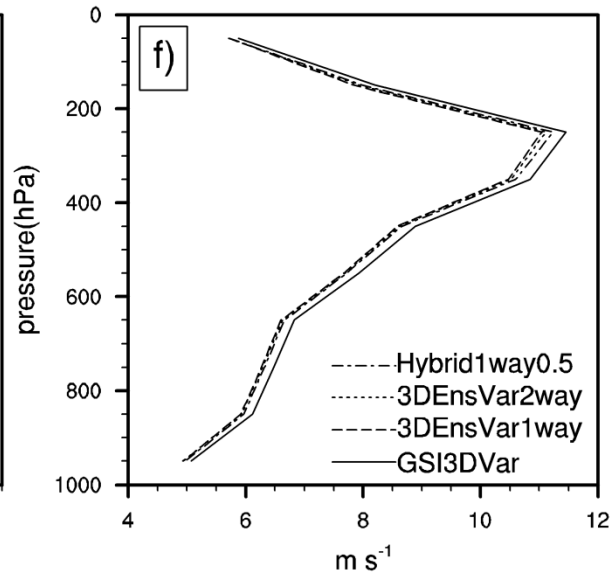

- 3DEnsVar Hybrid was better than 3DVar due to use of flow-dependent ensemble covariance
- 3DEnsVar Hybrid was better than EnKF due to the use of tangent linear normal mode balance constraint

Wang, Parrish, Kleist and Whitaker, MWR, 2013



GSI hybrid for GFS: 3DEnsVar vs. 4DEnsVar



Its 4D extension (4DEnsVar, no TL and ADJ of the forecast model) showed further improvement.

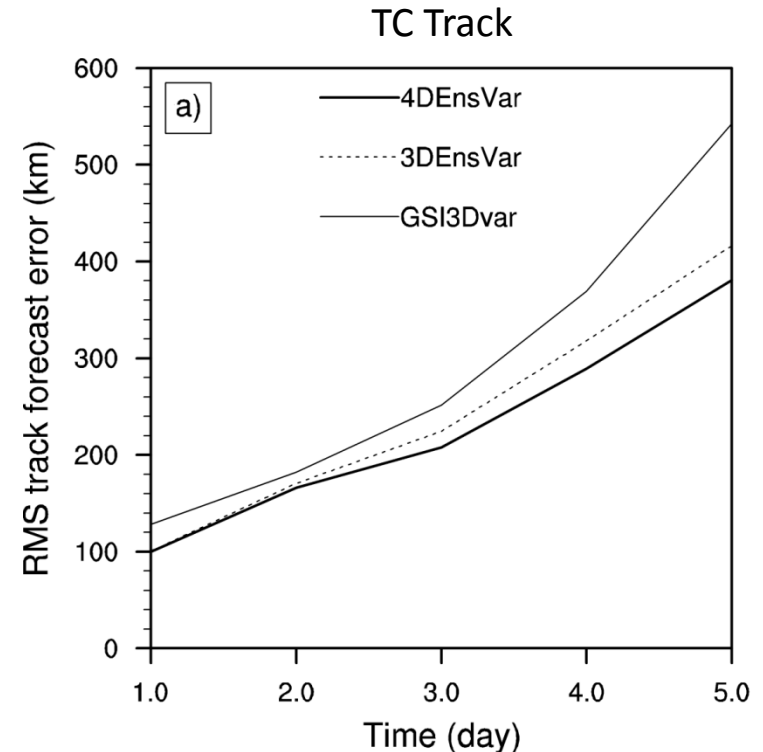
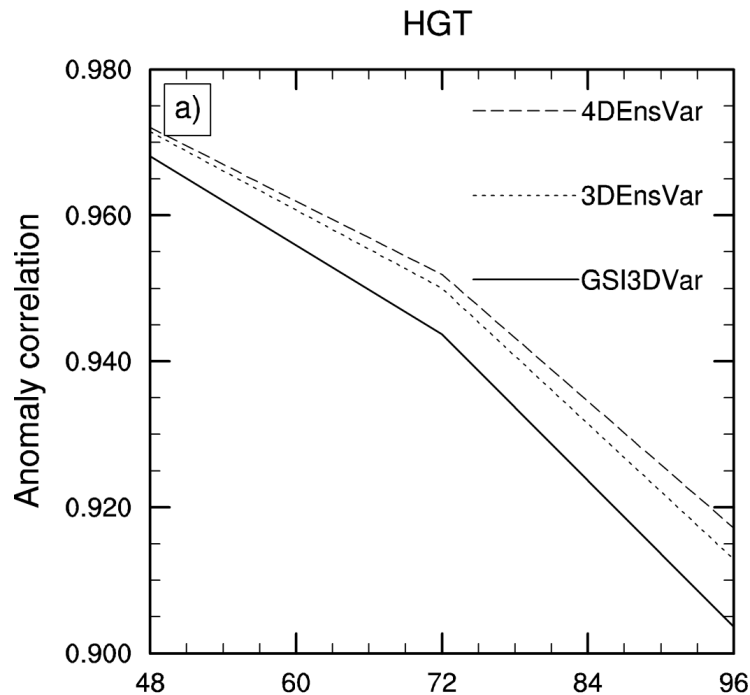

Wang and Lei, MWR, 2014



GSI-based Hybrid EnKF-Var DA system

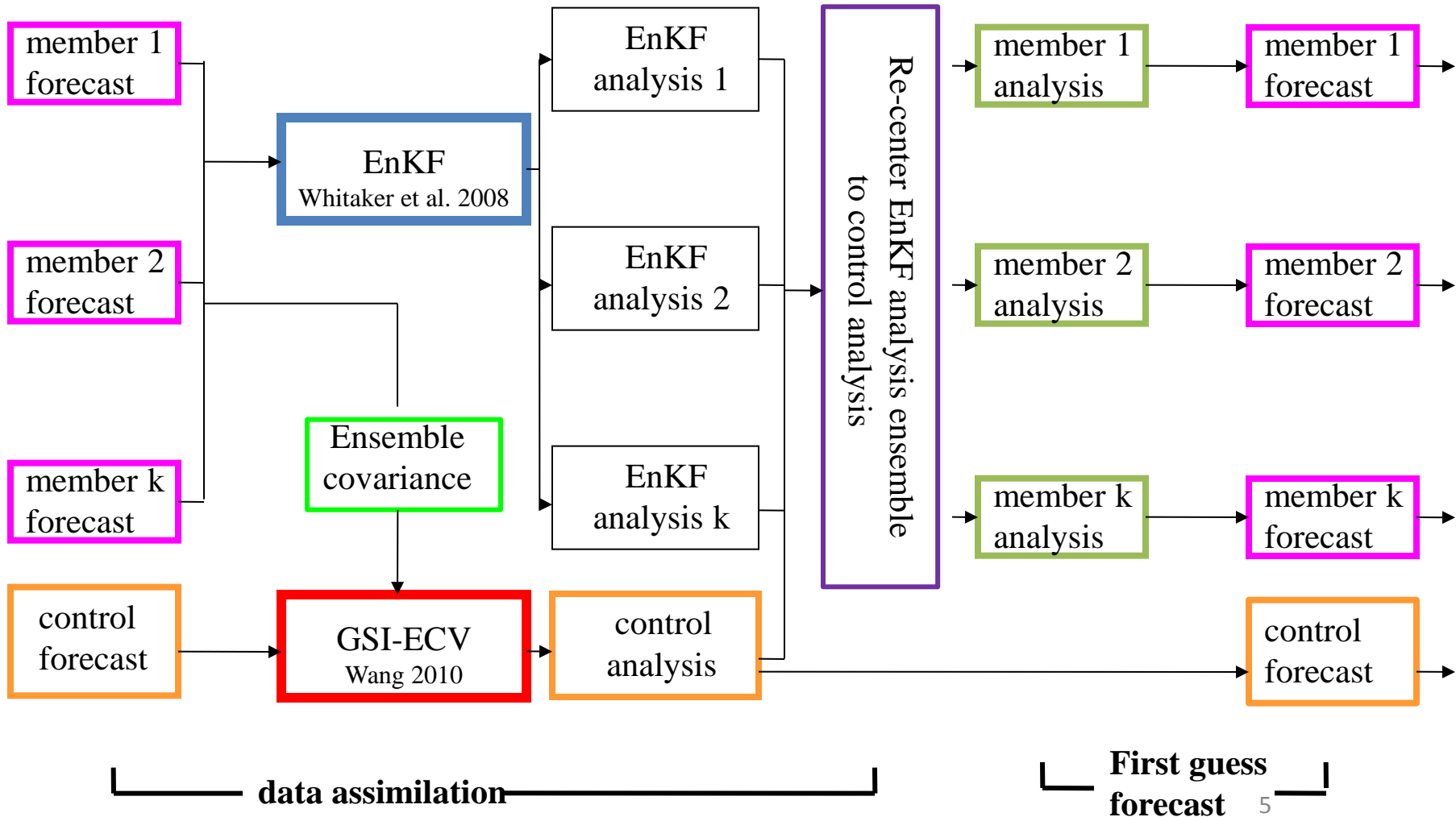



GSI-based Hybrid EnKF-Var DA system

- **EnKF**: square root filter interfaced with GSI observation operator (Whitaker et al. 2008)
- **GSI-ECV**: Extended control variable (ECV) method implemented within GSI variational minimization (Wang 2010):

$$\begin{aligned} J(\mathbf{x}'_1, \boldsymbol{\alpha}) &= \beta_1 J_1 + \beta_2 J_e + J_o \\ &= \beta_1 \frac{1}{2} \mathbf{x}'_1{}^T \mathbf{B}^{-1} \mathbf{x}'_1 + \beta_2 \frac{1}{2} \boldsymbol{\alpha}^T \mathbf{C}^{-1} \boldsymbol{\alpha} + \frac{1}{2} (\mathbf{y}^{o'} - \mathbf{H}\mathbf{x}')^T \mathbf{R}^{-1} (\mathbf{y}^{o'} - \mathbf{H}\mathbf{x}') \end{aligned}$$

Extra term associated with extended control variable

$$\mathbf{x}' = \mathbf{x}'_1 + \sum_{k=1}^K (\boldsymbol{\alpha}_k \circ \mathbf{x}_k^e)$$

Extra increment associated with ensemble



Background

- Efforts are being conducted to integrate the same or portions of GSI-based hybrid DA system with operational regional forecast systems (e.g., RAP (WRF ARW); HWRF; NAM, etc.).

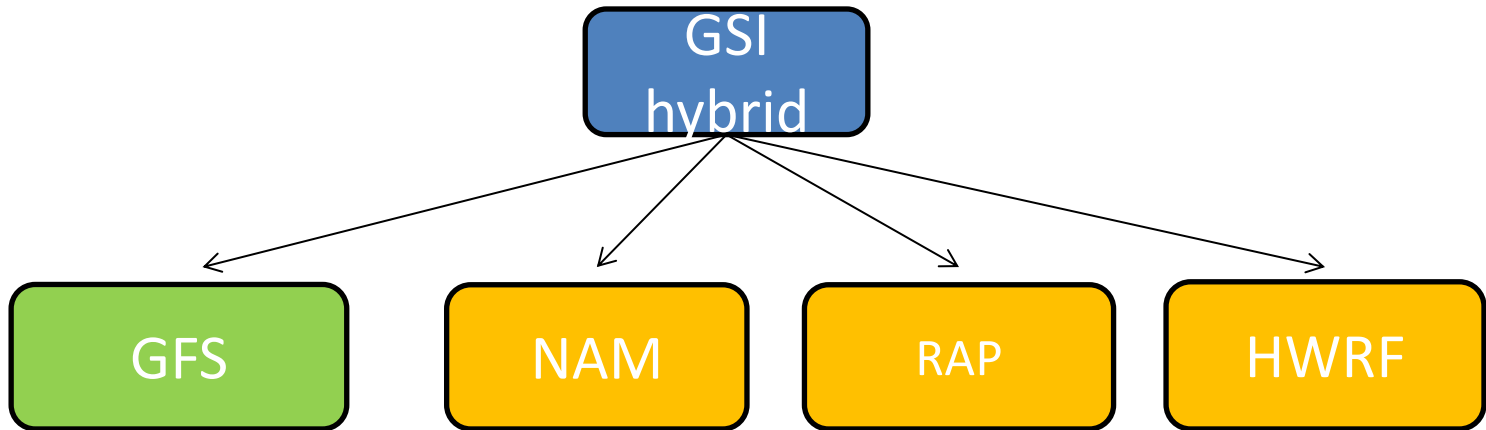

- Current operational HWRF hybrid DA (FY13) ingests GFS ensemble.
- In this study, both GSI-based EnKF and GSI-ECV are integrated with HWRF where GSI-based EnKF produces HWRF's own ensemble.
- The focus of this presentation is the extension, application, testing and research of the GSI-based EnKF-Var hybrid for HWRF by assimilating airborne radar data.



Hurricane Sandy, Oct. 2012



- Complicated evolution
- Tremendous size
- 147 direct deaths across Atlantic Basin
- US damage \$50 billion

New York State before and after
nhc.noaa.gov



Experiment Design

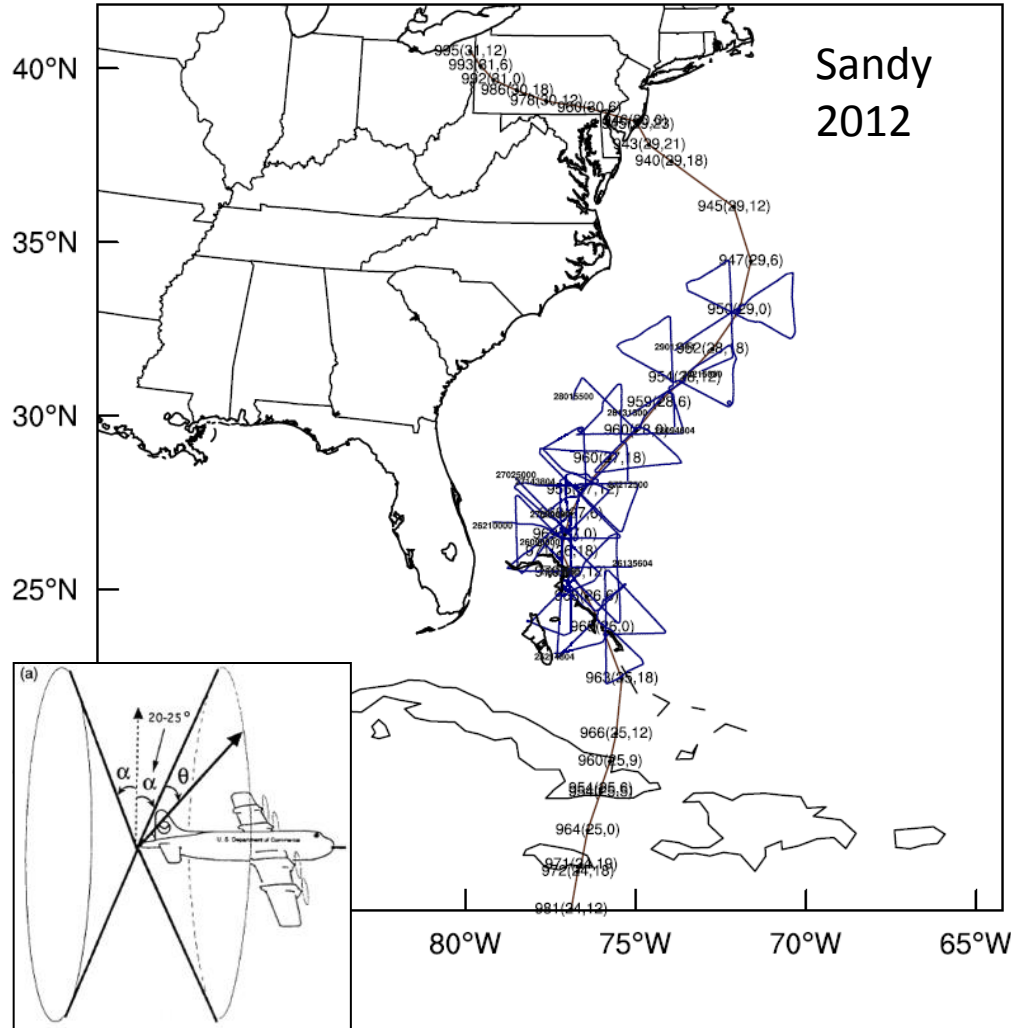

- Model: HWRF
- Observations: radial velocity from Tail Doppler Radar (TDR) onboard NOAA P3 aircraft
- Initial and LBC ensemble: GFS global hybrid DA system
- Ensemble size: 40



Experiment Design

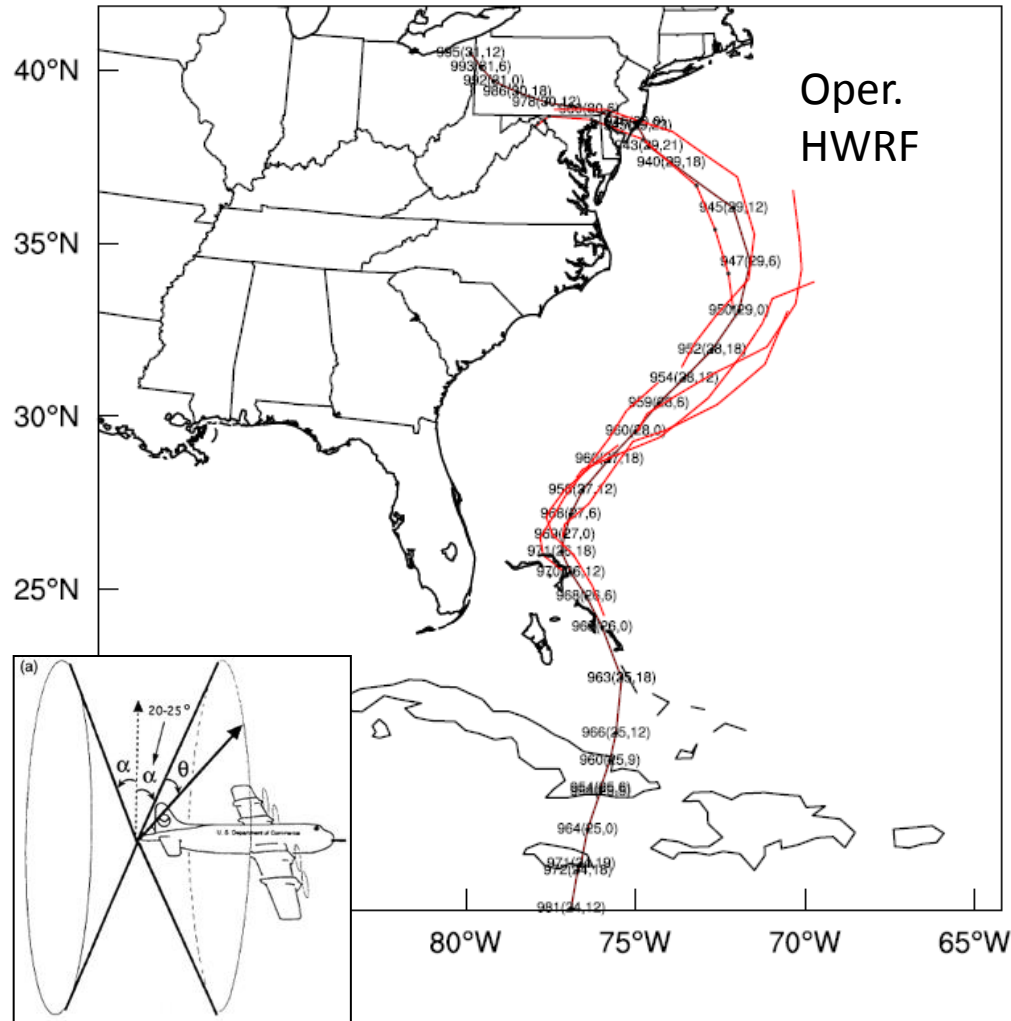

- Model: HWRF
- Observations: radial velocity from Tail Doppler Radar (TDR) onboard NOAA P3 aircraft
- Initial and LBC ensemble: GFS global hybrid DA system
- Ensemble size: 40



DA cycling configuration (mission 1)

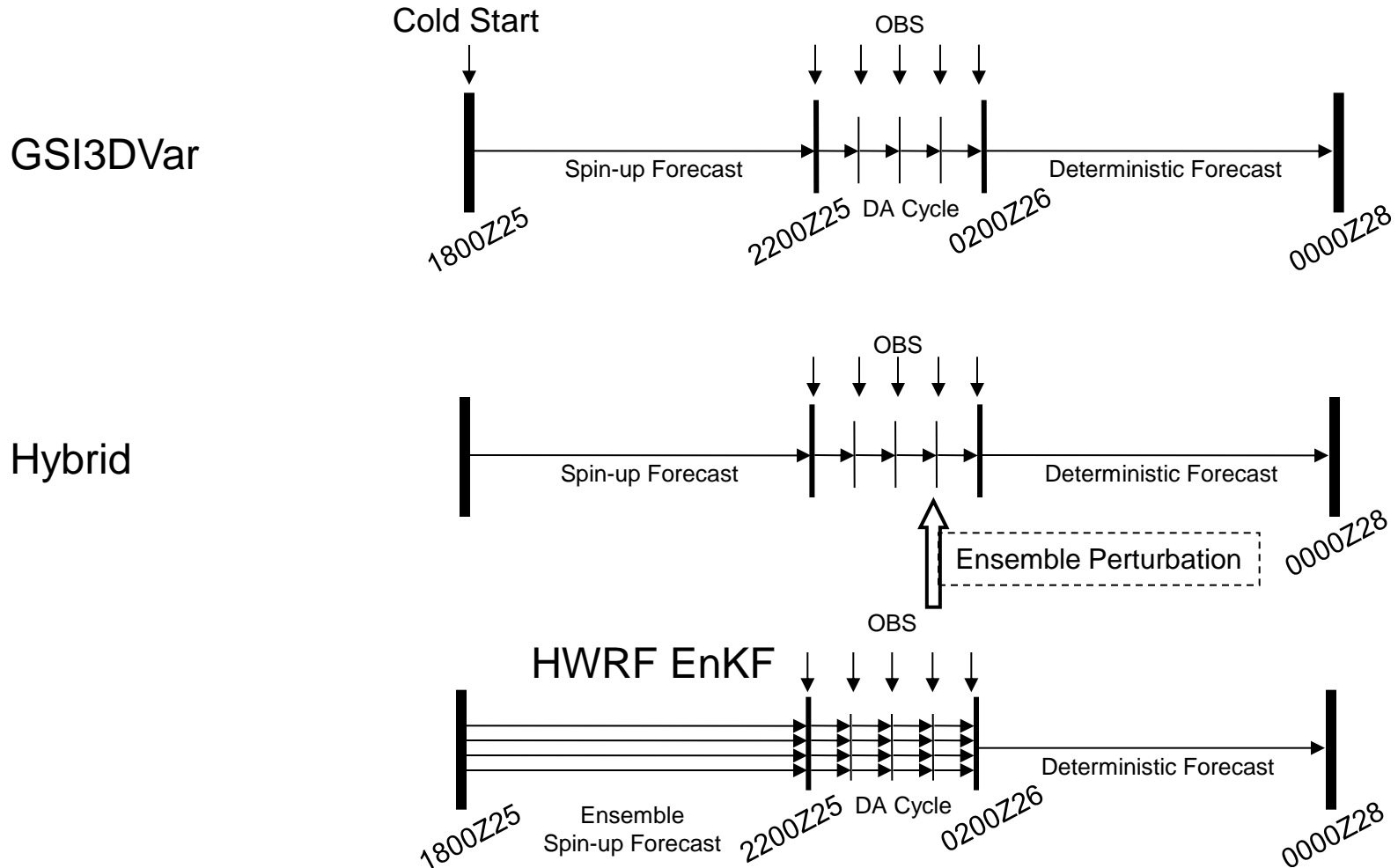



DA cycling configuration (mission 1)

Hybrid-GFSENS

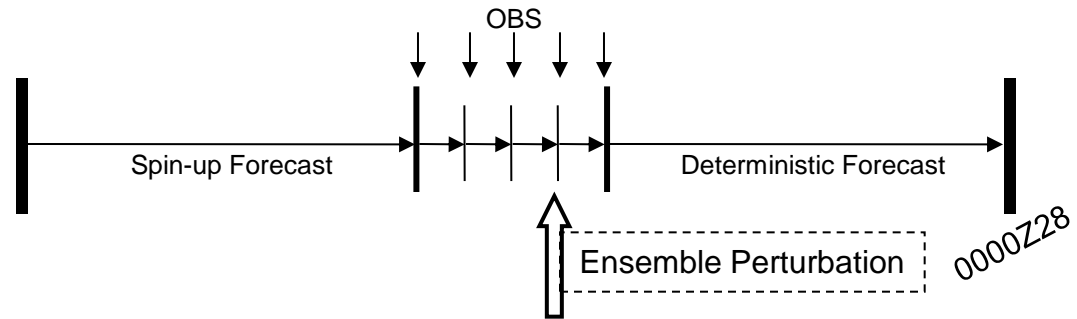

GFS ENS

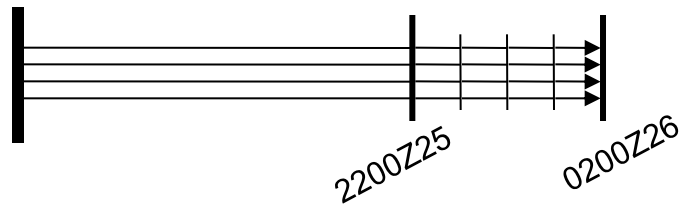

TDR data distribution (mission 1)

P3 Mission 1

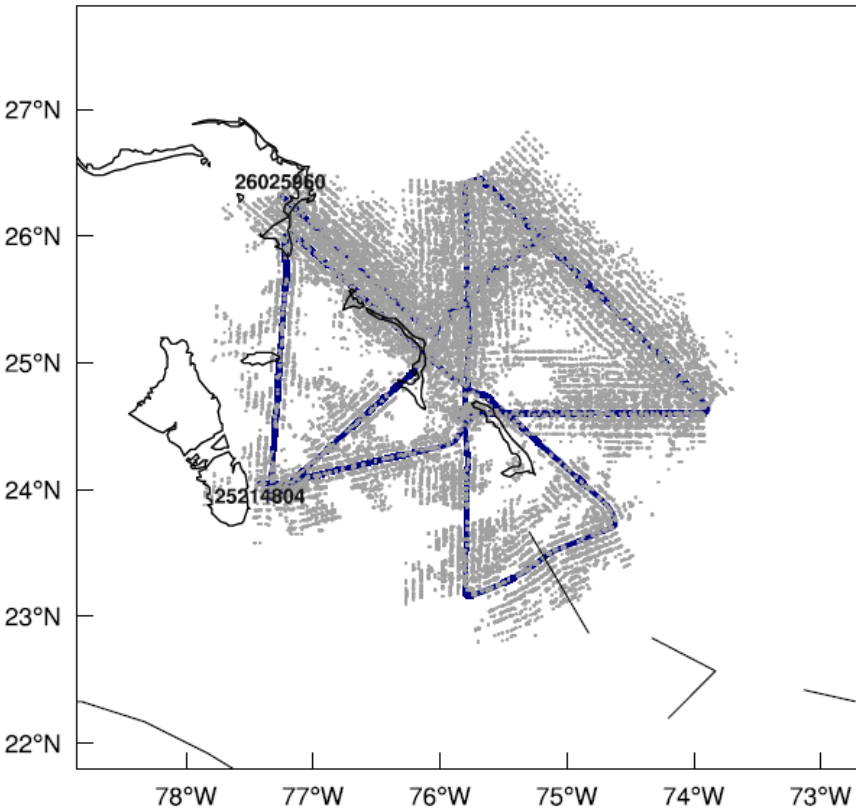

Vr vertical distribution

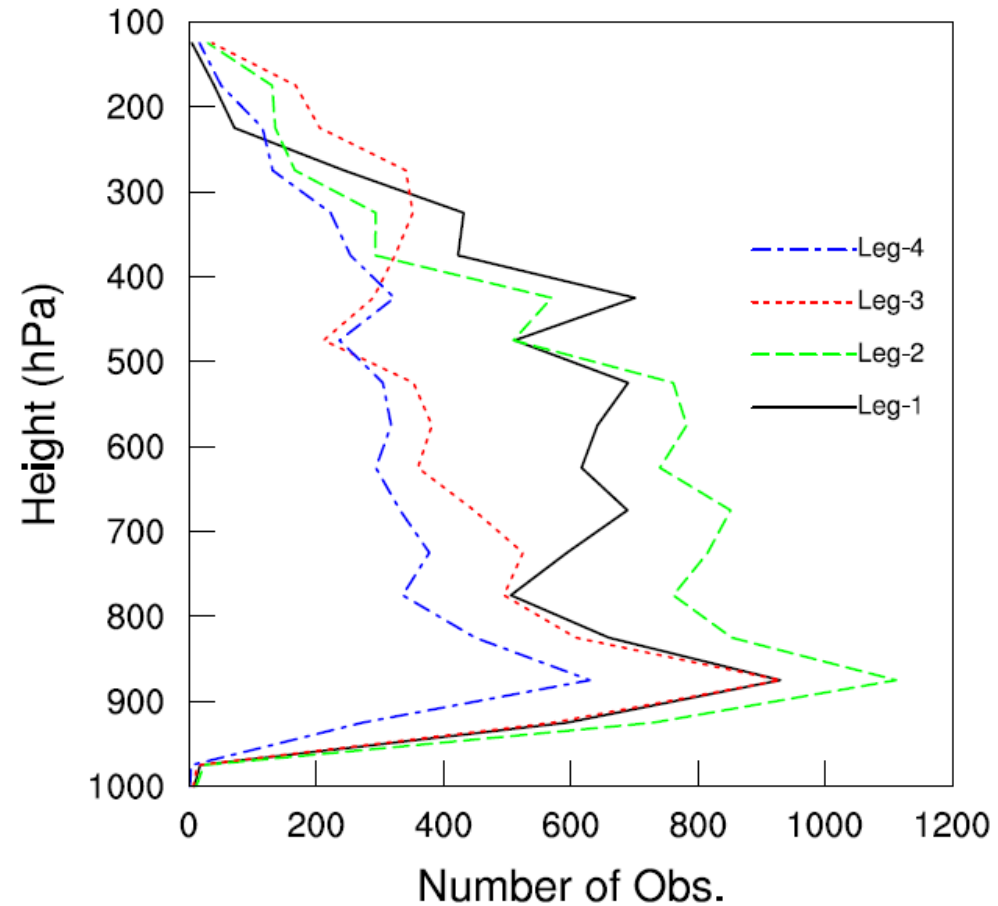



Verification against SFMR wind speed

First Leg

GSI3DVar-leg1-sws

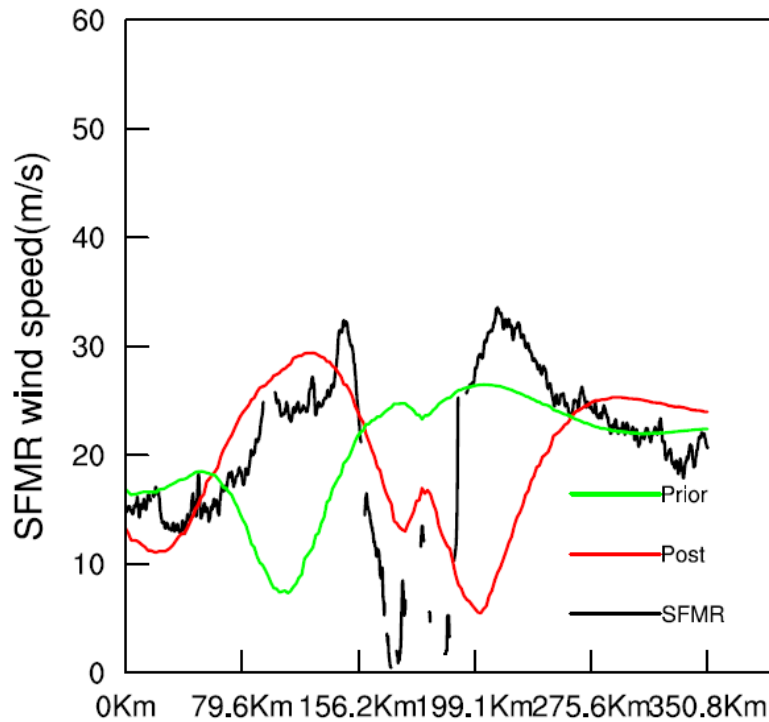

Hybrid-leg1-sws

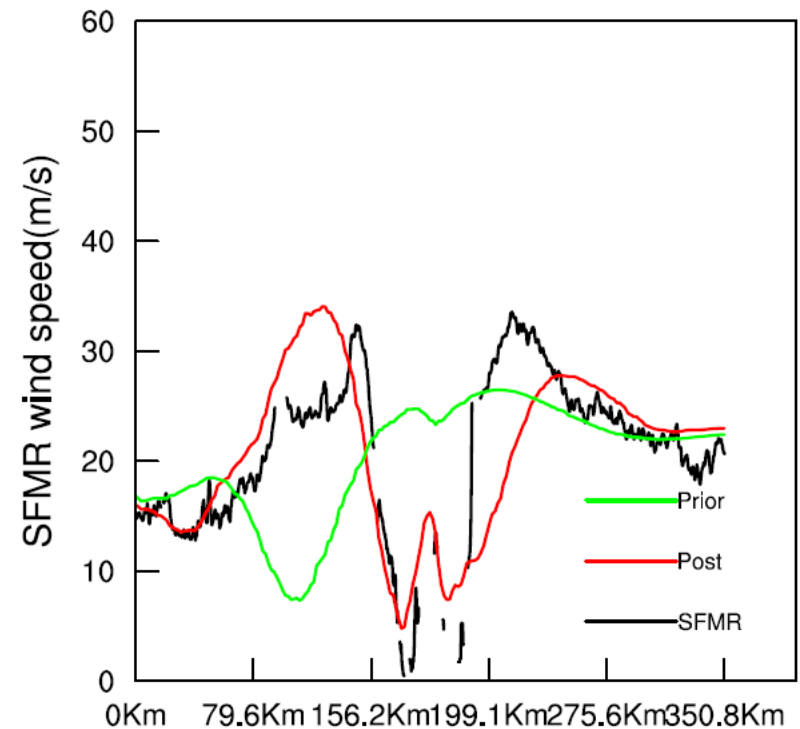



Verification against SFMR wind speed

Last Leg

GSI3DVar-leg4-sws

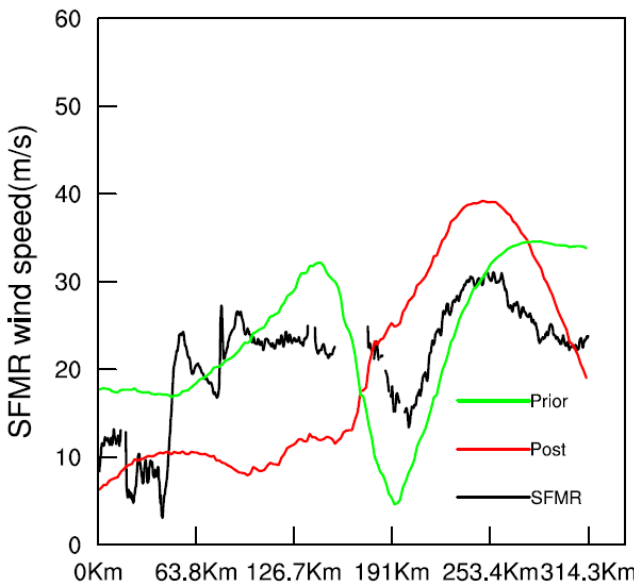

Hybrid-leg4-sws

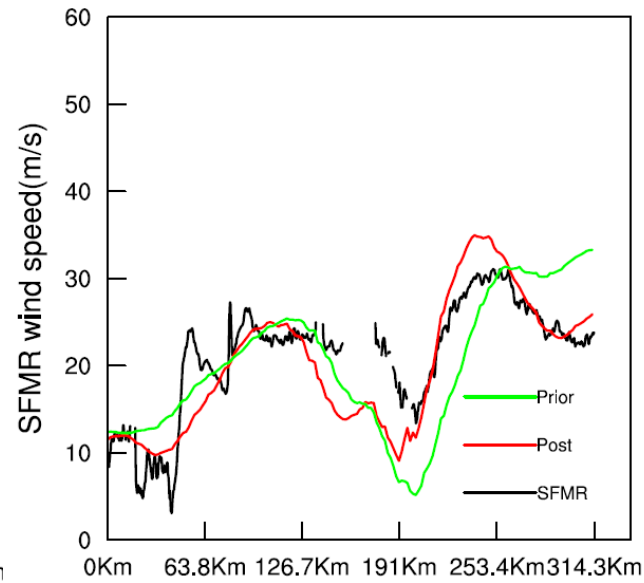

NoDA-leg4-sws

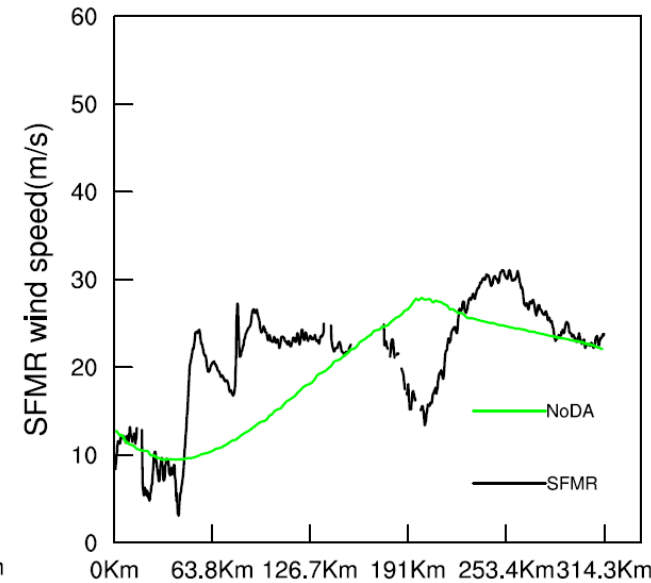



Comparison with HRD radar wind analysis

HRD radar @1km 00Z26

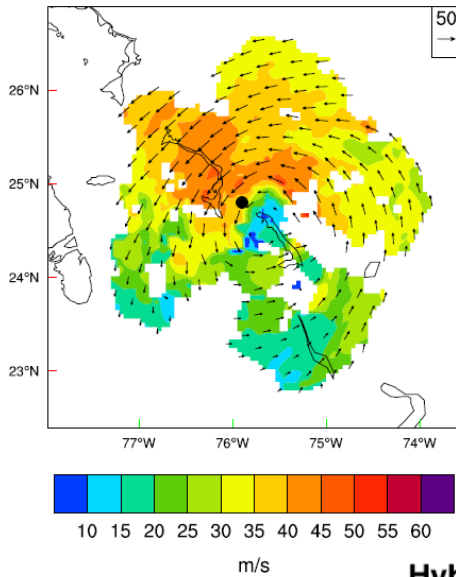

NoDA @1km 0230Z26

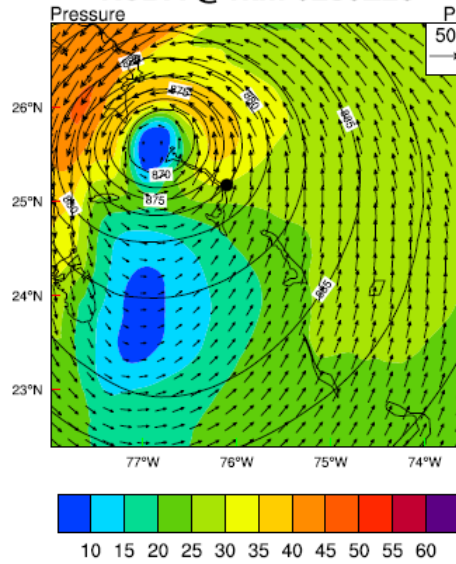

GSI3DVar @1km 0230Z26

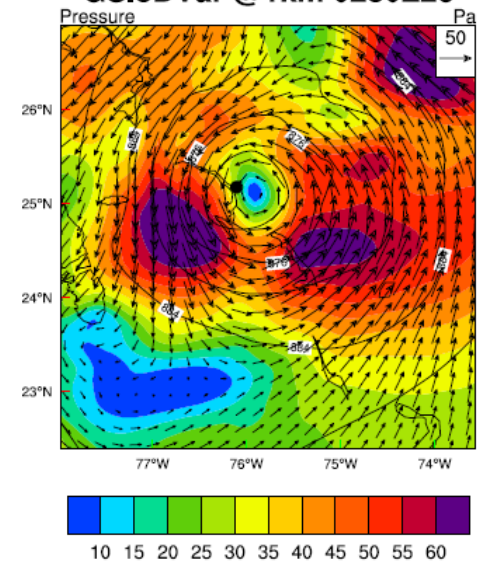

Hybrld @1km 0230Z26

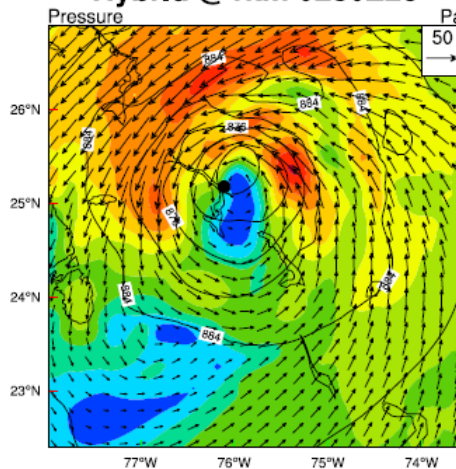

Hybrld-GFSENS @1km 0230Z26

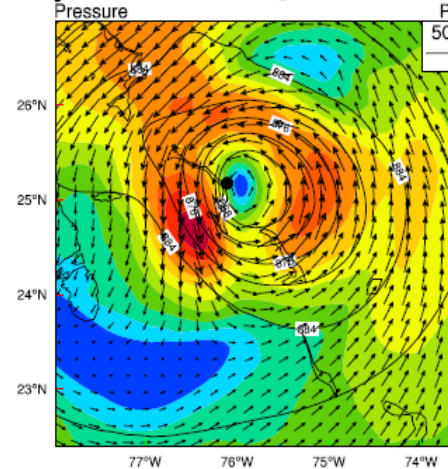



Comparison with HRD radar wind analysis

HRD radar along lon 00Z26

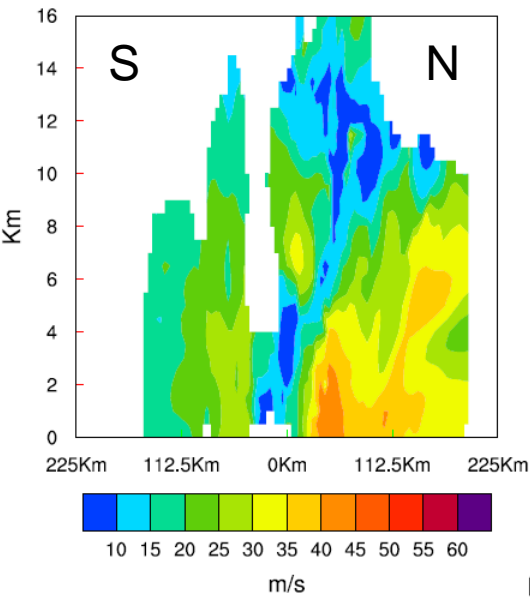

NoDA 0230Z26

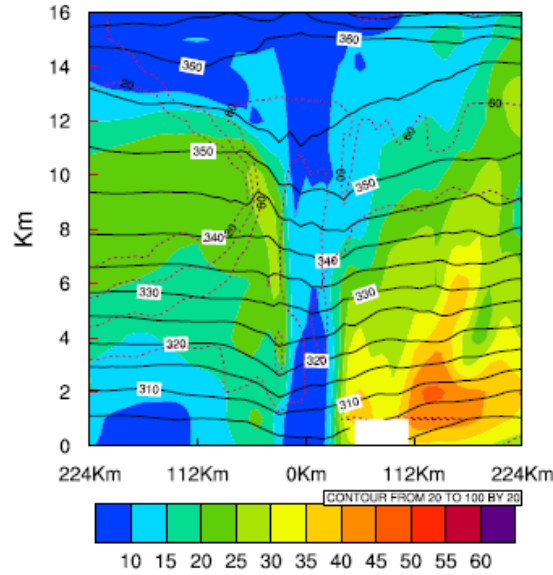

GS13DVar 0230Z26

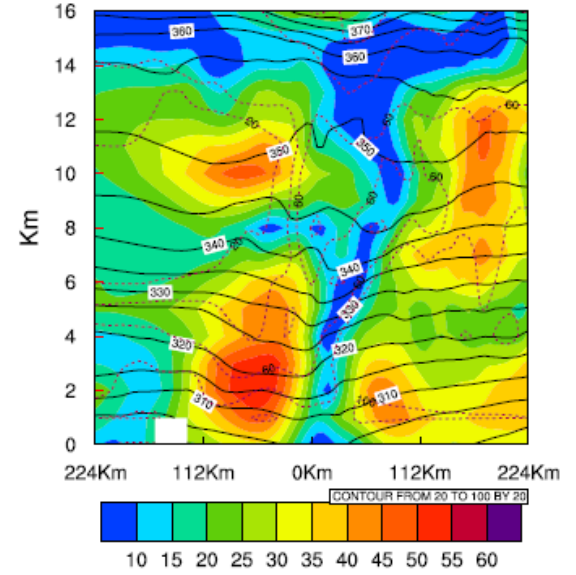

Hybrid 0230Z26

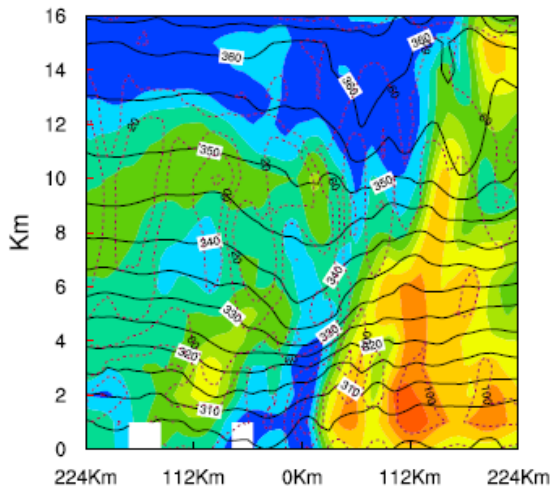

m/s

Hybrid-GFSENS 0230Z26

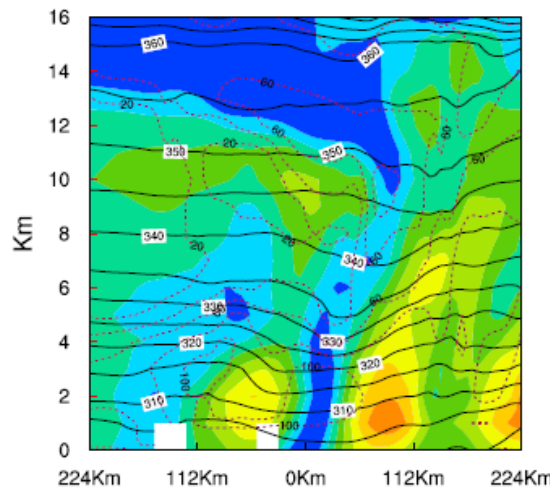

m/s



Track forecast (RMSE for 7 missions)

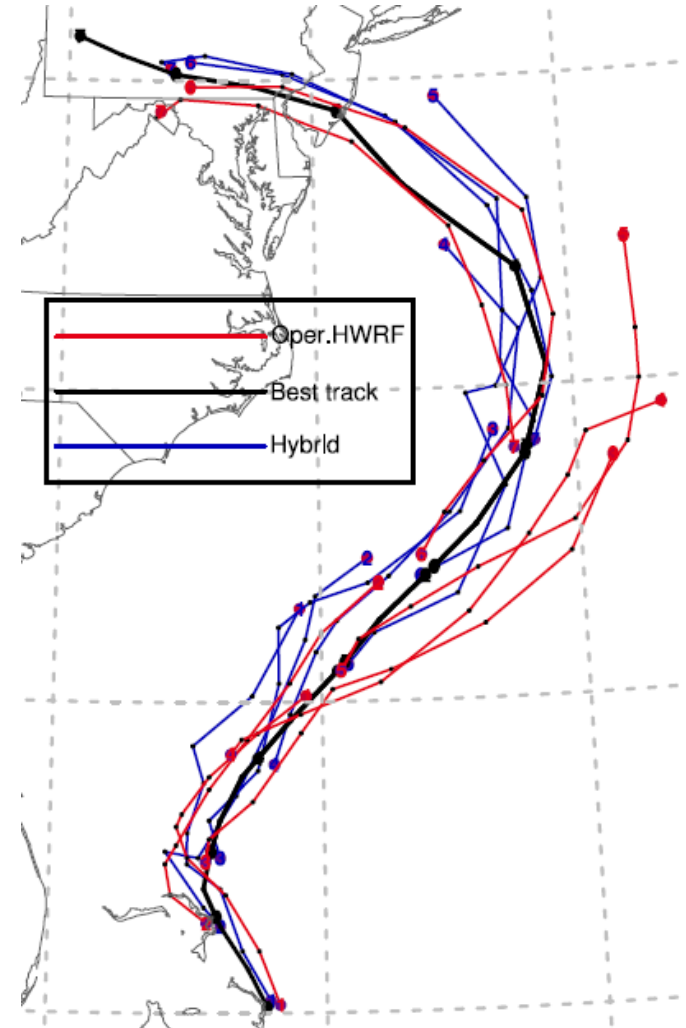
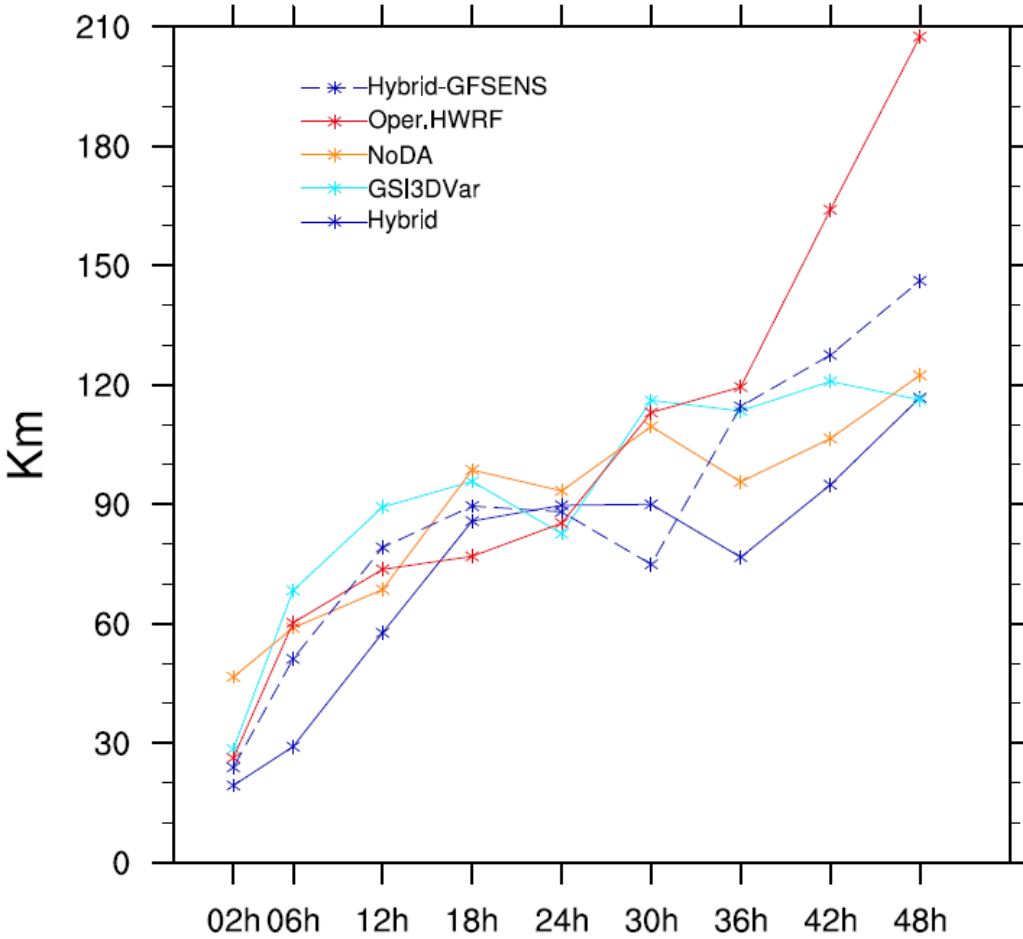



Max wind and MSLP relationship

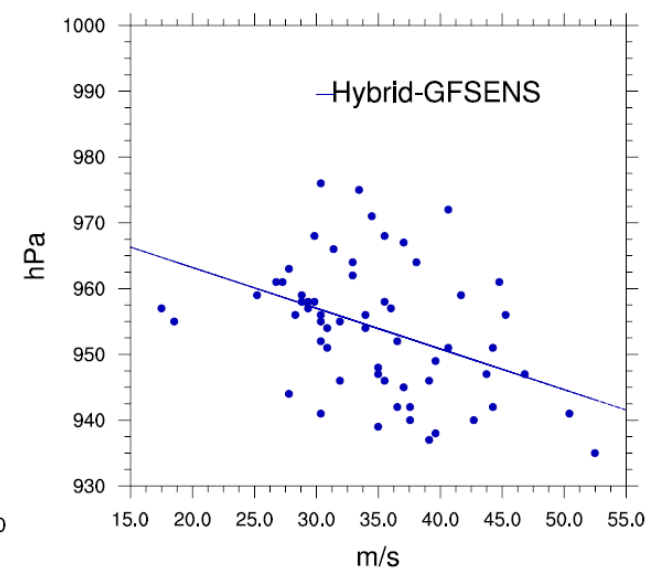
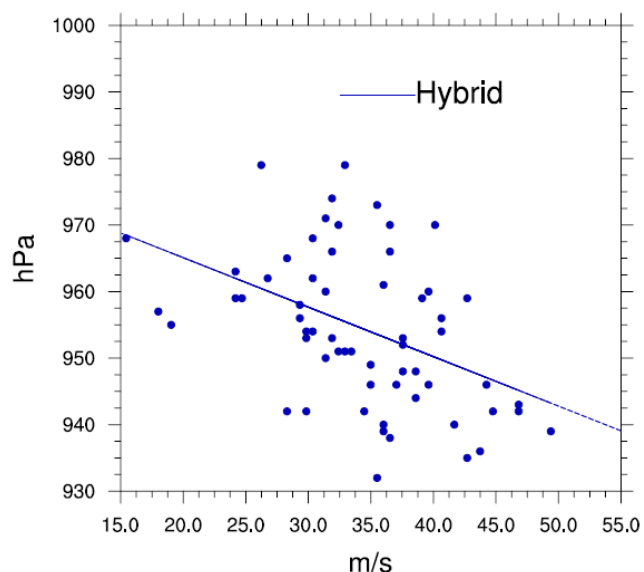
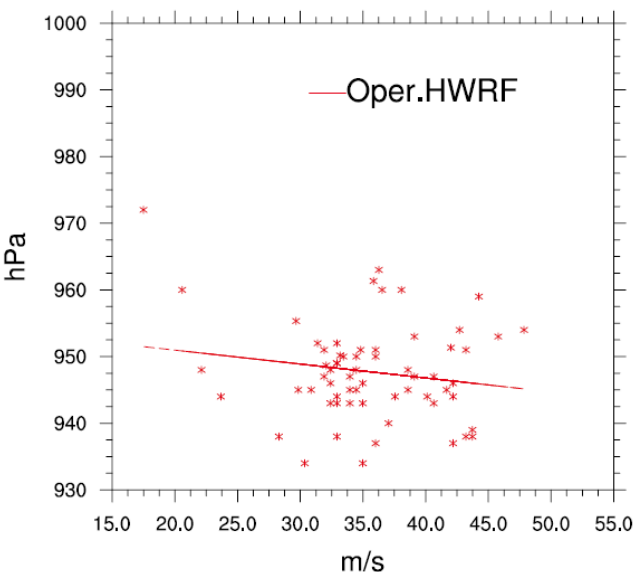
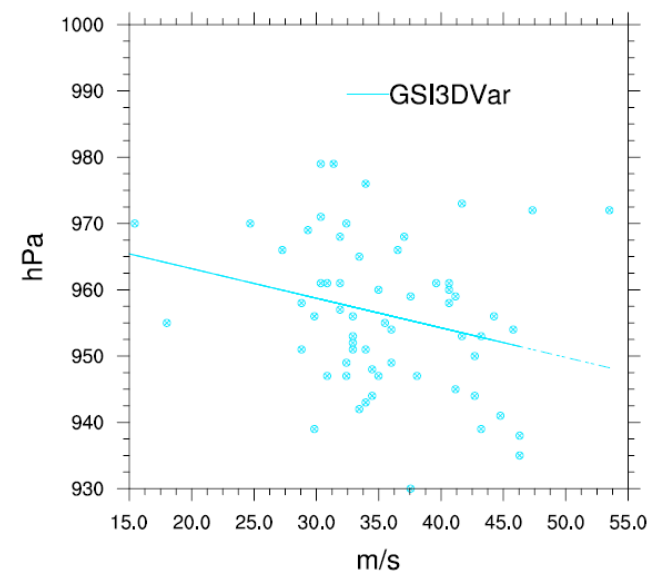
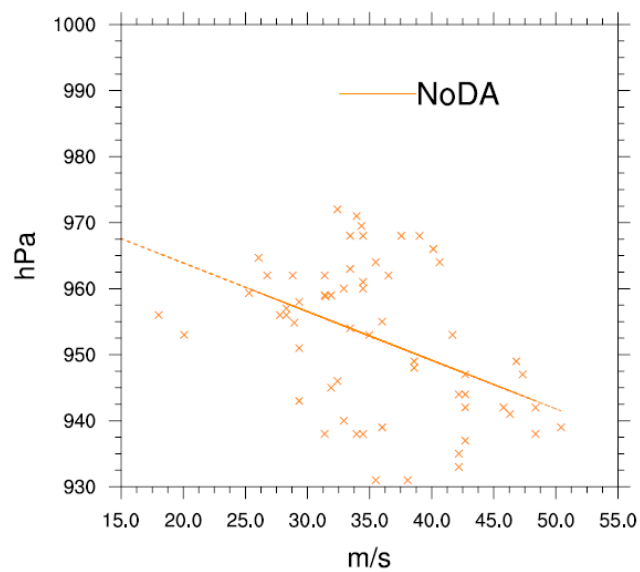
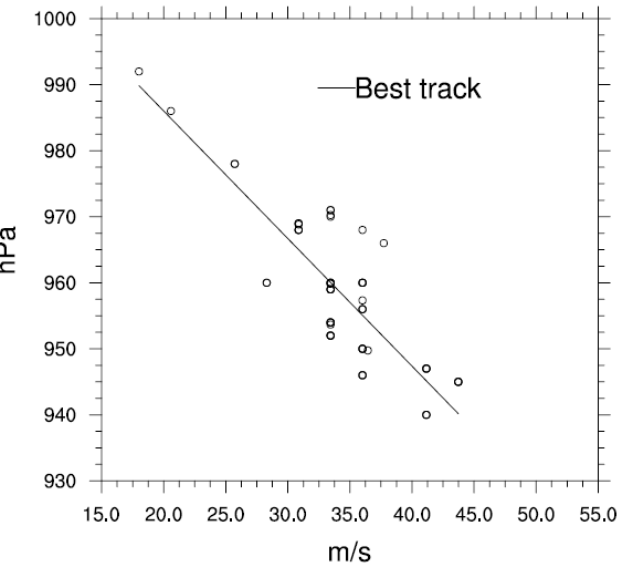



Experiments for 2012-2013 season

Correlation between HRD radar wind composite and analyses from various DA methods

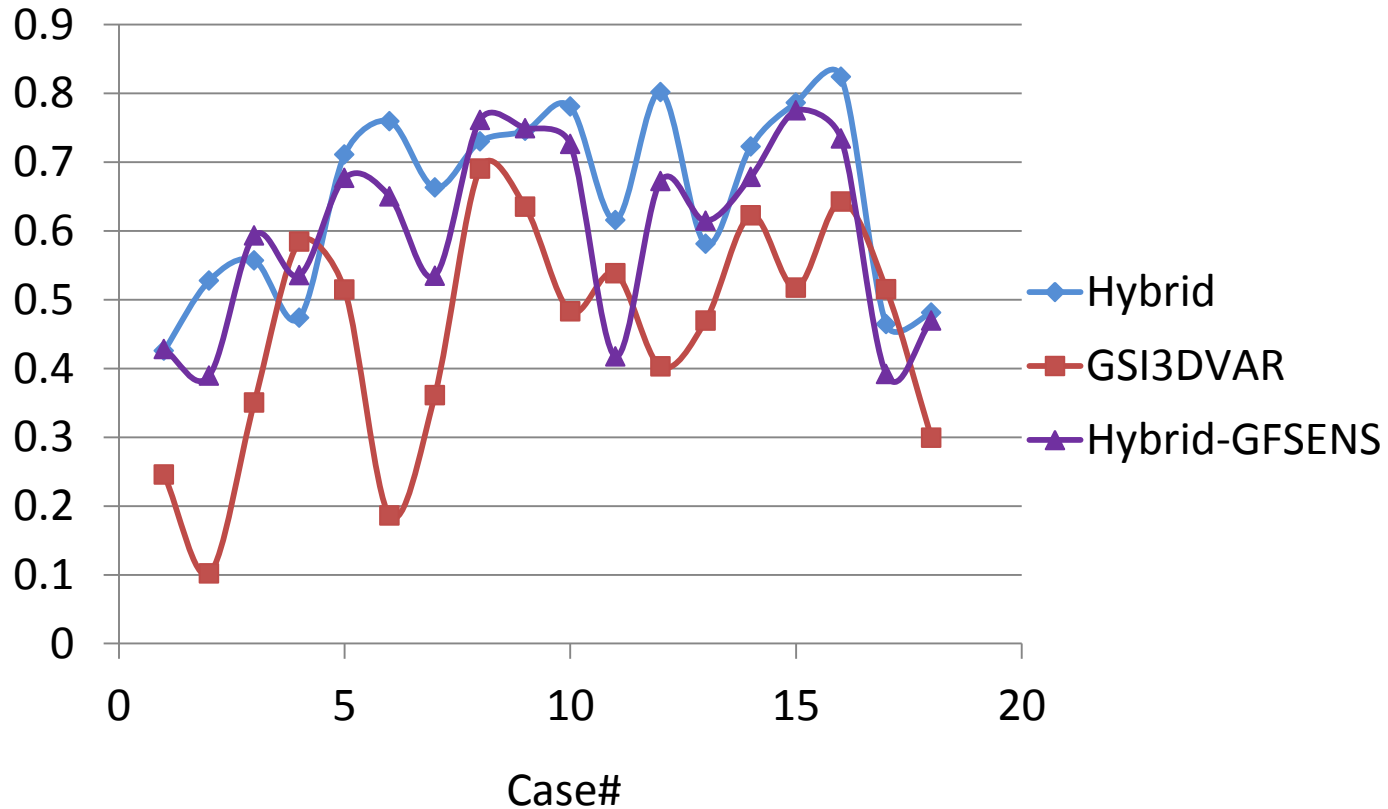



ISSAC 2012 (mission 7)

HRD radar @1km 00Z28

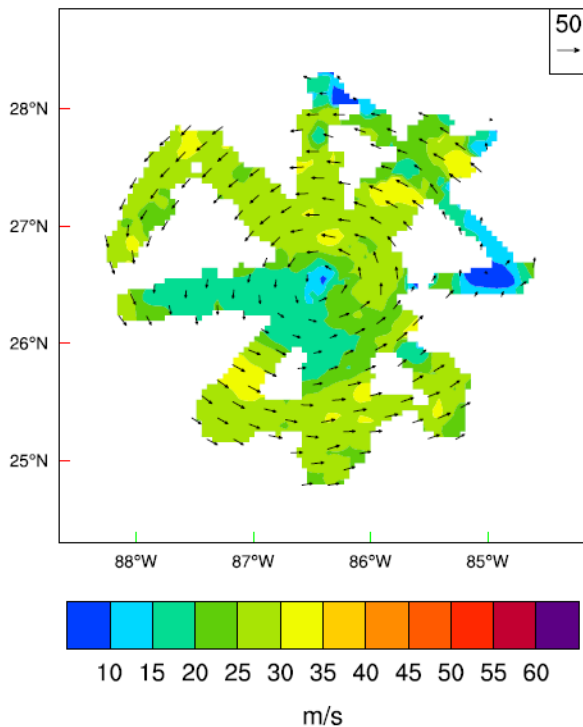

Hybrid @1km 02Z28

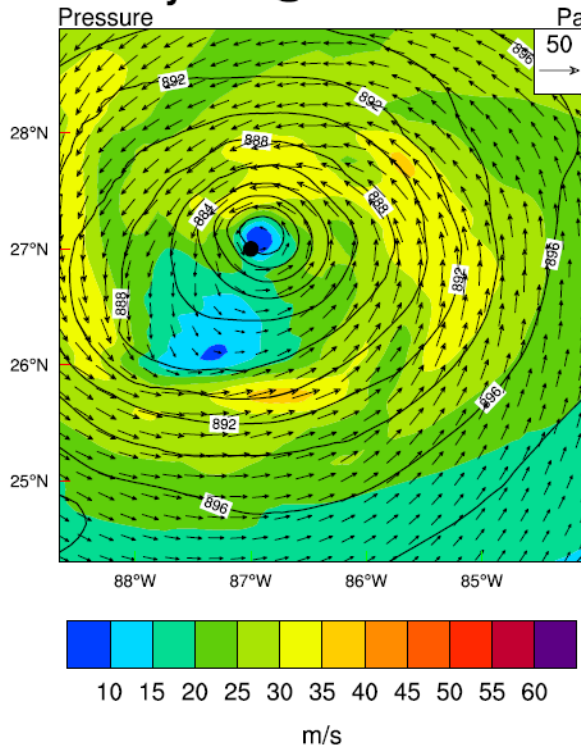

Hybrid-GFSSENS @1km 02Z28

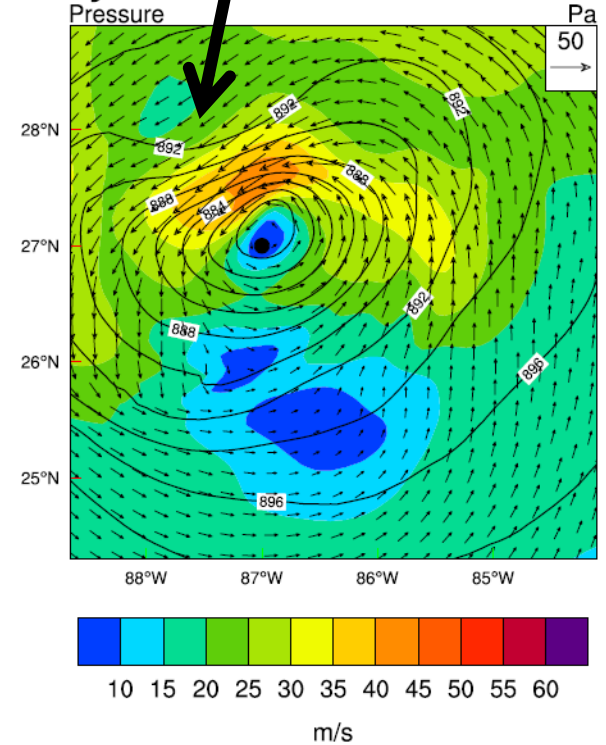



ISSAC 2012 (mission 7)

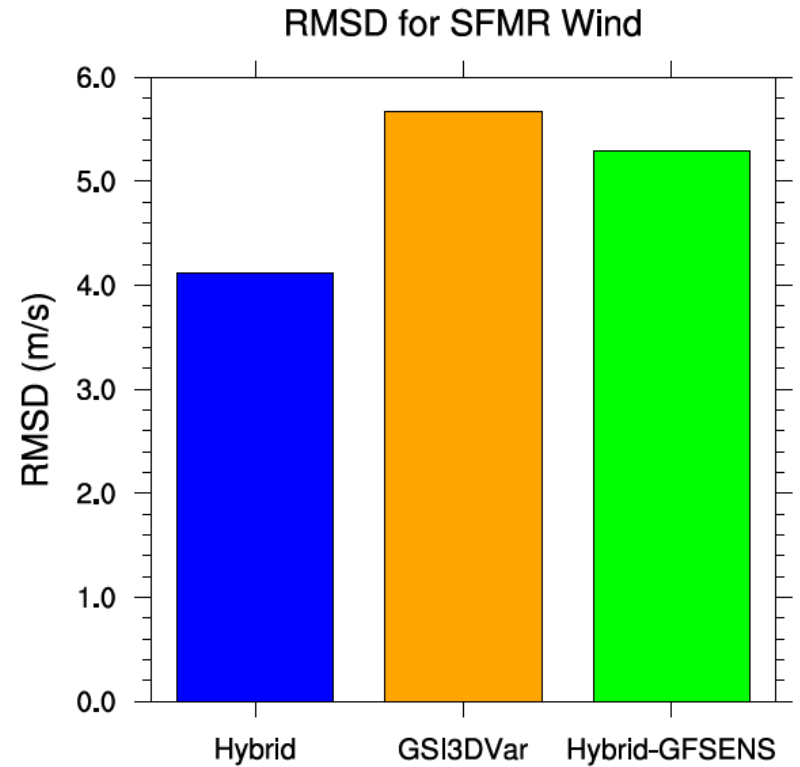
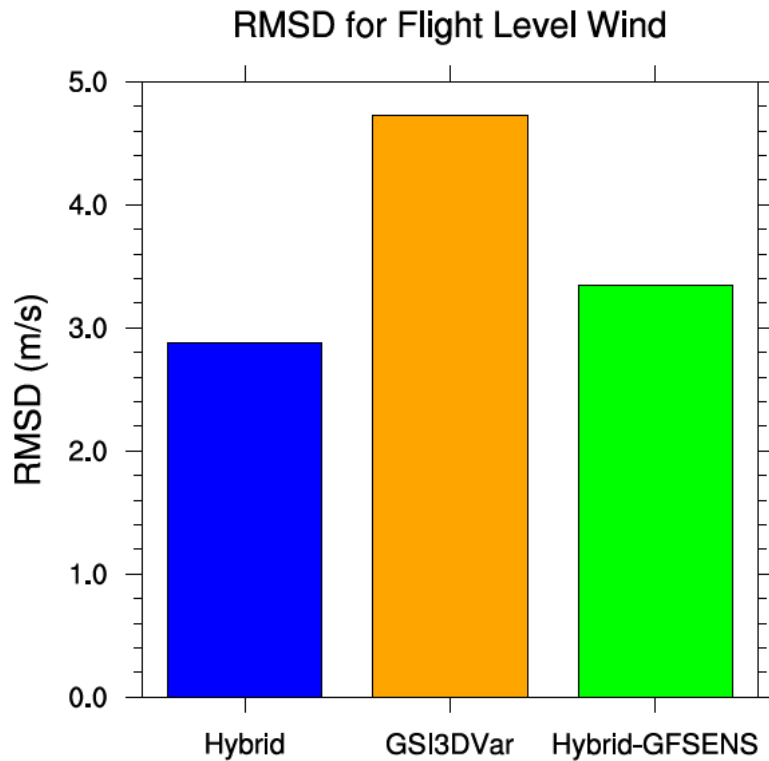



Experiments for 2012-2013 season

Track

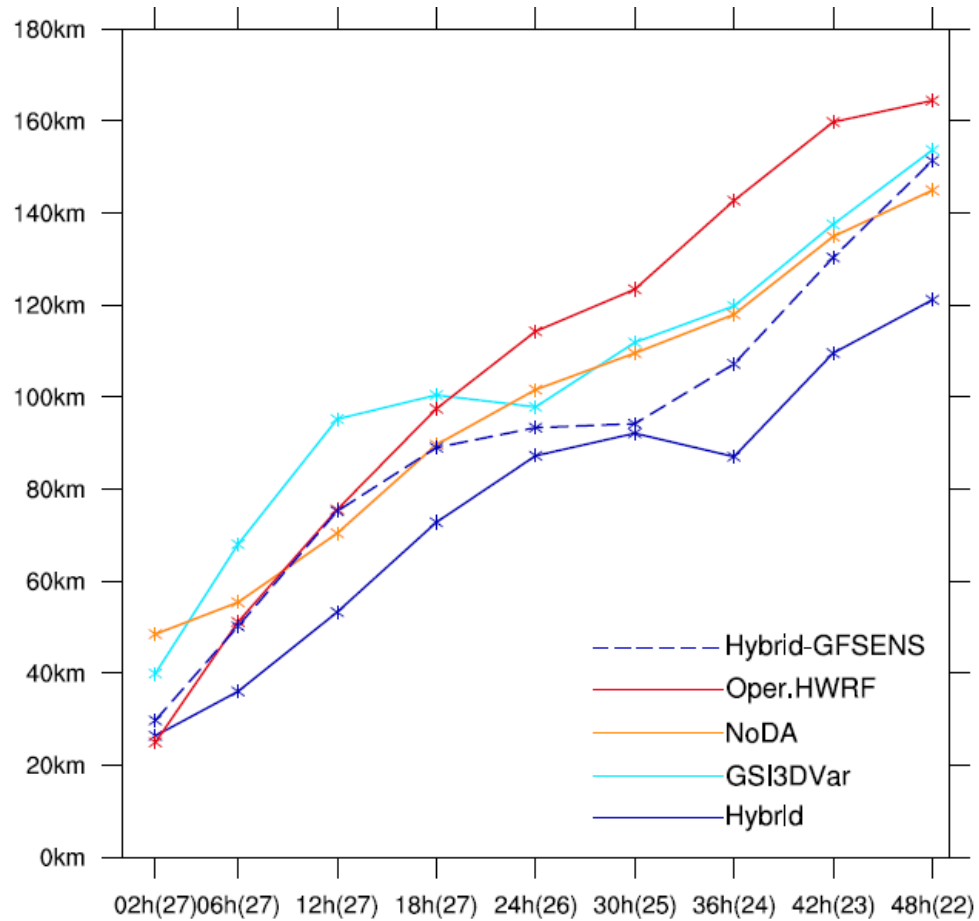



Experiments for 2012-2013 season

MSLP

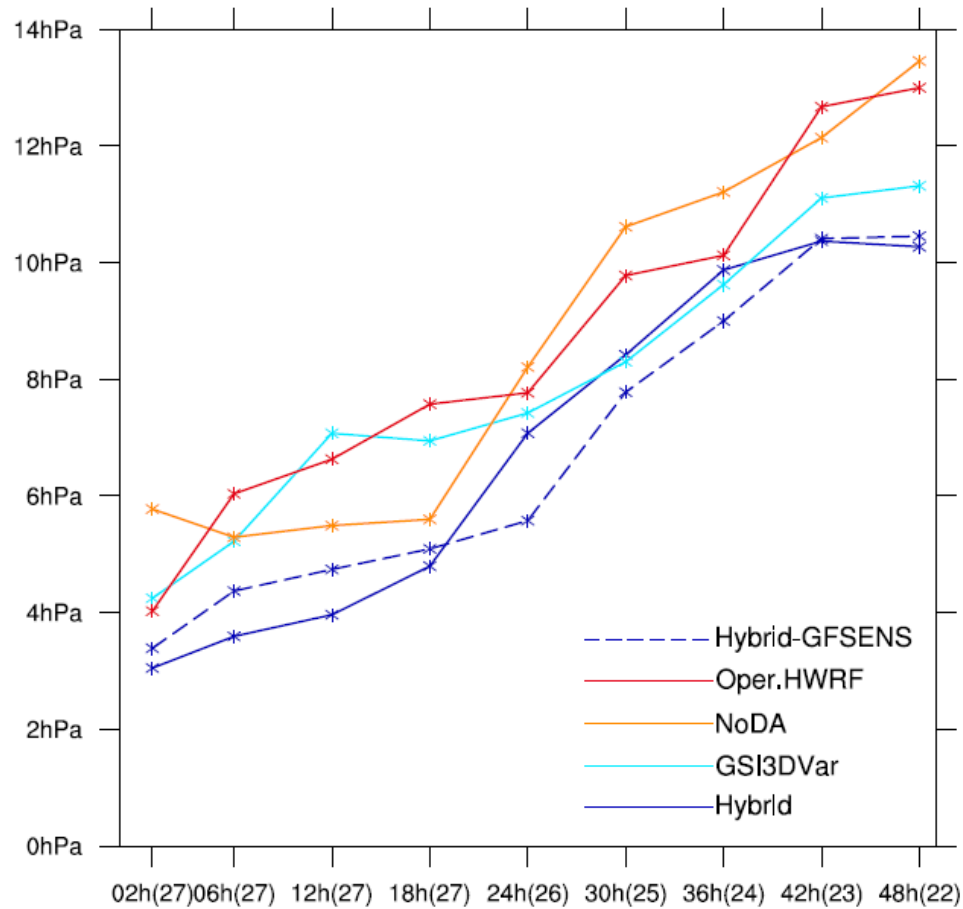



Experiments for 2012-2013 season

Max Wind

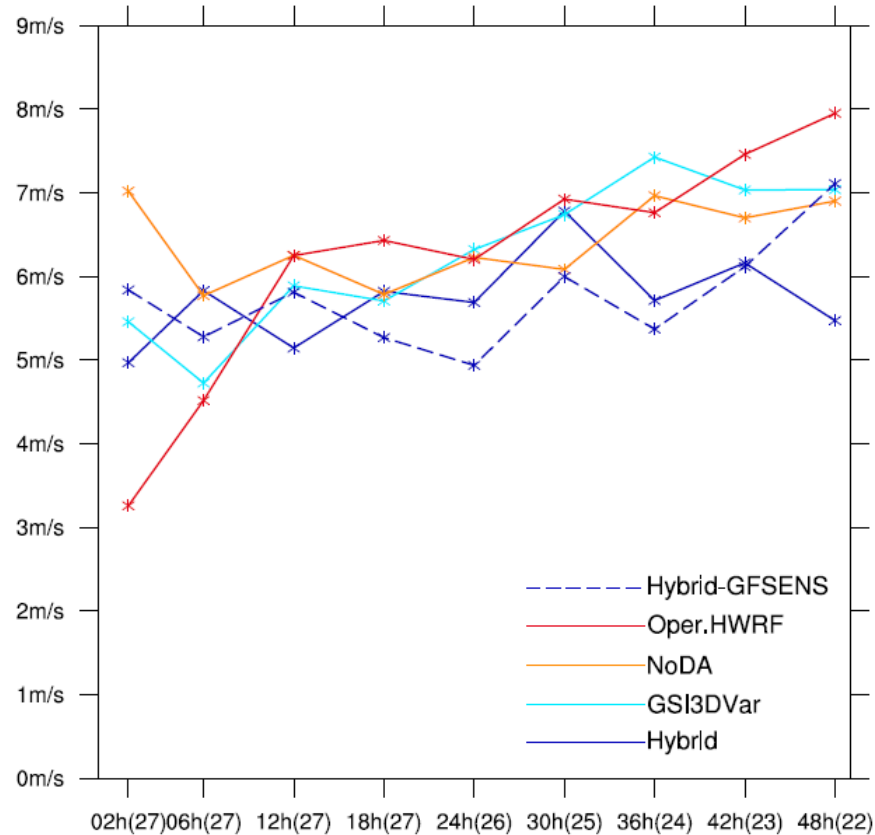



Summary and ongoing work

- a. The unified GSI-based hybrid EnKF-Var data assimilation system including both the Var (GSI-ECV) and EnKF components were expanded to HWRF.
- b. Airborne radar data assimilation capability was enhanced for GSI hybrid DA for HWRF.
- c. The system was tested using retrospective cases over Atlantic during 2012 season and was tested in near real time during 2013 season.
- d. Various diagnostics and verifications suggested this unified GSI hybrid DA system provided more skillful TC analysis and forecasts than GSI 3DVar and more skillful TC analysis and track forecasts than HWRF GSI hybrid ingesting GFS ensemble.
- e. Airborne radar data improved TC structure analysis and forecast, TC track and intensity forecasts. Impact of the data depends on DA methods.
- f. We are enhancing the unified hybrid system with dual-resolution (3km-9km) two way hybrid, 4DEnsVar hybrid, EnKF with moving nest capability during DA, and assimilation of other airborne data and other data from NCEP operational data stream.